

# Study and Analysis of Design Optimization and Synthesis of Robotic ARM

Bhupender<sup>1</sup>, Rahul<sup>2</sup>

<sup>1</sup>Department of ME, CBS Group of Institution, Jhajjar, Haryana, India

<sup>2</sup>Assistant Professor, Department of ME, CBS Group of Institution, Jhajjar, Haryana, India

**Abstract**— A robot is a mechanical or virtual artificial agent, usually an electro-mechanical machine that is guided by a computer program or electronic circuitry. Robots can be autonomous or semi-autonomous. In this thesis, design optimization strategies and synthesis for robotic arm are studied. In the design process, novel optimization methods have been developed to reduce the mass of the whole robotic arm. The optimization of the robotic arm is conducted at three different levels, with the main objective to minimize the robot mass.

At the first level, only the drive-train of the robotic arm is optimized. The design process of a robotic arm is decomposed into selection of components for the drive-train to reduce the weight

At the second level, kinematic data is combined with the drive-train in the optimization. For this purpose, a dynamic model of the robot is required. Constraints are formulated on the motors, gearboxes and kinematic performance

At the third level, a systematic optimization approach is developed, which contains design variables of structural dimensions, geometric dimensions and drive-train composes.

Constraints are formulated on the stiffness and deformation. The stiffness and deformation of the arm are calculated through FEA simulation.

The main objective of the thesis is to design optimization and synthesis analysis of robotic arm. The corresponding deflections, stresses and strains for that load will be find out by suing the method of finite element analysis.

**Keywords**— robotic arm, inverse kinematics, dynamics, Jacobian method, motor selection and drive train optimization.

## I. INTRODUCTION

A robotic arm is a type of mechanical arm, usually programmable, with similar functions to the human arm; the arm may be the sum total of the mechanism or may be part of a more complex robot. The links of such a manipulator are connected by joints allowing either rotational motion (such as in an articulated robot) or translated (linear) displacement. The links of the

manipulator can be considered to form a kinematic chain of the manipulator is called the end effectors and it is analogous to the human hand.

In this section, I look at some basic arm geometries. As I said before, a robot arm or manipulator is composed of a set of joints, links, grippers and base part. The joints are where the motion in the arms occurs, while the links are of fixed construction. Thus the links maintain a fixed relationship between the joints. The joints may be actuated by motors or hydraulic actuators.

## II. ROBOT OPTIMIZATION AND SYNTHESIS

### • DRIVE TRAIN OPTIMIZATION

A general method of motor and gearbox selection and optimization of servo drive system was introduced. The method automated the solution procedure for the servo drive design problem by virtue of the normalization of torques, velocities, and transmission ratios. Moreover, and selection criteria separated the motor characteristics from the load characteristics and its graphical representation facilitated the feasibility check of a certain drive and the comparison between different systems. These methods above are applicable to the design of a single joint combining a motor and a gearbox, and they do not address the discrete nature of the selection process. For design of robotic drive train consisting of multiple joints, the challenge is that not only the characteristics of motor and gearbox at a single joint, but also the dynamics of the robot should be taken into account. An early attempt on drive-train design optimization can be found in which Chasnal and Gautier proposed a method for the optimum selection of robot actuators of minimize the total mass of all actuators. The modeling of the system took into account the inertia of the links and actuators, viscous and Coulomb friction effects, and the thermal model of the actuators as well.

### • Dimensional Optimization

Dimensional optimization can contribute to the improvement of robotic performance, either kinematic performance or dynamic one. An integrated structure-control design optimization method of a two-link flexible robot arm was presented, where the structural and control

parameters were optimized simultaneously. The method used a genetic algorithm and the performance was compared with that of an arm with uniform links and an optimized control system. The simultaneous optimization yielded a design with higher bandwidth and less weight of the arm system. An optimal design of manipulator parameter using an evolutionary optimization method was proposed in which a modification in differential evolution optimization technique was proposed to incorporate the effect of noises in the optimization process and obtain the optimal design of a manipulator. An optimum robot design method based on a specified task was proposed in which dimensions were optimized based on dynamic analysis. Three evolutionary techniques were applied to minimize the torque required to perform the defined motion subject to constraints on link parameters and the end-effectors deflection.

• **Structural optimization**

Single arm robot design of structural parts may lead to a significant reduction in the weight of the robot. Regarding structural optimization, finite element analysis (FEA) is widely used. FEA was utilized to conduct structural topology optimization in the design of humanoid robots. Multimode system simulation (MBS) was employed to investigate the dynamics of the robot. By integrating MBS simulation into structural optimization processes, components in mechatronic systems could be optimized regarding the interaction between parts of mechanical properties and the overall system dynamics. FEA based design optimization was conducted on a 2-dof robot to minimize the vibration frequency. The optimized design was compared with an experimental investigation of the structure vibration frequencies design obtained on the actual manipulator. The utilization of FEA in robotic arm design and structural optimization can be found.

The above robotic optimization technologies are summarized in Table 1.1.

N	Objective	Design Variables	Constraints	Optimization algorithm
1	Total mass	Motor mass	Minimize motor torques	KTNC <sup>1</sup>
2	Mass, cost	Motor torques	Motor, joint dynamics	Complex
3	Control performance	Controller, drive train	Dynamic	Pattern search, GA <sup>2</sup>
4	Dynamic	Motor selection	Motor torques	---

	performance			
5	Control performance	Structural dimensions	Control	GA
6	Kinematics and dynamic performance	Geometric dimension, link mass	Boundary limits	GA
7	Joint torques	Structural dimensions	Stiffness, deflection	GA

<sup>1</sup> Kuhn-Tucker Necessary Conditions

<sup>2</sup> Genetic Algorithm

• **Design considerations**

The robotic arm is an anthropomorphic arm as it follows the nature design of a human arm. A human arm consists of seven dof, three at the shoulder, two at the elbow, and two at the wrist. The concept design of the robotic arm includes 5 dof, which reduces one dof in the shoulder and one in the elbow. When the concept design has been determined the physical properties from the design can be used to recalculate motions and torques. These can then again be used to redesign the first concept to a new and better one. This iteration process would be efficient to put inside an optimization procedure, where motors, gearboxes and structural design would be optimization factors.

The robotic arm will be used to handle daily tasks of people assistance applications. The total reach distance is 1 m (without the gripper), which is a bit longer than a human arm. The workspace of each joint is based on the corresponding joint workspace of the human arm.

Table: Joint workspace of the robotic arm

Joint i	Max Workspace	Constrained Workspace
1	$0 \sim 2\pi$	$0 \sim \pi$
2	$0 \sim 3\pi/2$	$0 \sim 3\pi/2$
3	$0 \sim 3\pi/2$	$0 \sim 3\pi/4$
4	$0 \sim 2\pi$	$0 \sim 2\pi$
5	$0 \sim 3\pi/2$	$0 \sim 3\pi/4$

**Kinematics**

Robot kinematics is the study of the motions (kinematics) of robots. In a kinematic analysis the position, velocity and acceleration of all the links are calculated without considering the forces that cause this motion.

Robot kinematics deals with aspect of redundancy, collision avoidance and singularity avoidance. While dealing with the kinematics used in the robot we deal each parts of the robot by assigning a frame of reference to it and hence a robot with many parts may have any individual frames assigned to each movable parts. For simplicity we deal with single manipulator arm or the robot. Each frames are named systematically with numbers, for example the immovable base part of the manipulator is numbered 0, and the first link joined to the base is numbered 1, and the next link 2 and similarly till n for the last nth link.

In the kinematic analysis of manipulator position, there are two separate problems solve: direct kinematics, and the inverse

kinematics. Direct kinematics involves solving the forward transformation equation to find the location of the hand in terms of the angles and displacements between the links. Inverse kinematics involves solving the inverse transformation equation to the find the relationships between the links of the manipulator from the location of the hand in space.

**III. BASIC MANIPULATOR GEOMETRIES**

In this types of the arm, mechanics of a manipulator can be represented as a kinematic chain of rigid bodies (links) connected by revolute or prismatic joints. One end of the chain is constrained to a base, while an end effector is mounted to the other end of the chain.

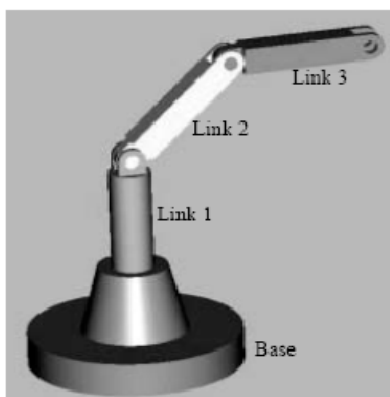

Fig.1:Shows an open chain serial robot arm

**Open chain manipulator kinematics**

In the open chain robot arm, The resulting motion is obtained by composition of the elementary motions of

each link with respect to the previous one. The joints must be controlled individually

**Closed Chain Manipulator Kinematics**

Closed Chain Manipulator is much more difficult than open chain manipulator. Even analysis has to take into account statics, constraints from other links, etc. Parallel robot is a closed chain. For this type of robots, the best example is the Stewart platform. Figure-3.2 shows Stewart platform.

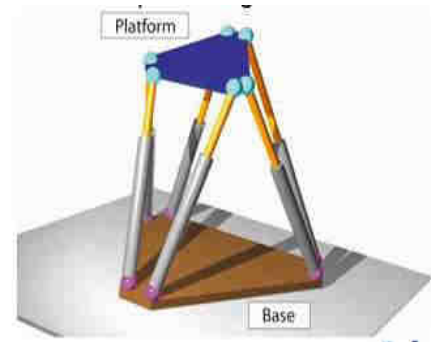

Fig.2:Stewart platform

**Homogenous Transformation**

Homogeneous transformation is used to calculate the new coordinate values for a robot part. Transformation matrix must be in square form. Figure-5.4 shows the transformation matrix.

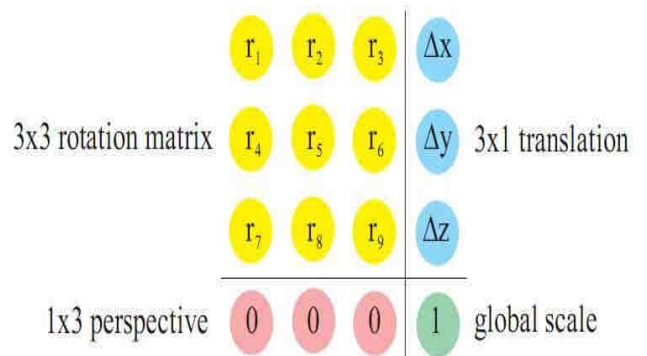

Fig.3:Homogeneous Transformation matrix.

3x3 rotation matrix may change with respect to rotation value. 3x1 translation matrix shows the changing value between the coordinate systems. Global scale value is fix and Also 1x3 perspective matrix is fix.

**Inverse Kinematics (IK)**

Inverse kinematics is the opposite of forward kinematics. This is when you have a desired end effector position, but need to know the joint angles required to achieve it. The inverse position kinematics (IPK) solves the following problem:"Given the actual end effector pose, what are the corresponding joint positions?" In contrast to the forward problem, the solution of the inverse problem is not always unique: the same end effector pose can be reached in several

configurations, corresponding to distinct joint position vectors. Although way more useful than forward kinematics, this calculation is much more complicated too.

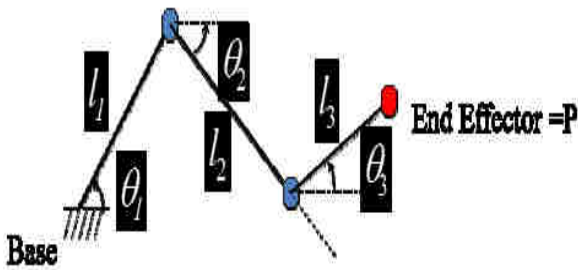

Fig.4: Inverse kinematics

The problems in IK :

- There may be multiple solutions,
- For some situations, no solutions,
- Redundancy problem.

**Solving The Inverse Kinematics**

Although way more useful than forward kinematics, this calculation is much more complicated. There are several methods to solve the inverse kinematics.

$$\text{Cos}(a) = \frac{A^2 + B^2 + C^2}{2AB} \quad (\text{Cosine Law.})$$

using the cosine law angles are found

$$\text{Cos}(\theta_T) = \frac{x}{\sqrt{x^2 + y^2}}$$

$$\theta_T = \cos^{-1}\left(\frac{x}{\sqrt{x^2 + y^2}}\right)$$

$$\text{Cos}(\theta_1 - \theta_T) = \frac{L_1^2 + x^2 + y^2 - L_2^2}{2L_1 \sqrt{x^2 + y^2}}$$

$$\theta_1 = \cos^{-1}\left(\frac{L_1^2 + x^2 + y^2 - L_2^2}{2L_1 \sqrt{x^2 + y^2}}\right) + \theta_T$$

$$\text{Cos}(180 - \theta_2) = \frac{L_1^2 + L_2^2 - (x^2 + y^2)}{2L_1 L_2}$$

$$\theta_2 = 180 - \cos^{-1}\left(\frac{L_1^2 + L_2^2 - (x^2 + y^2)}{2L_1 L_2}\right)$$

**Inverse Jacobian Method**

It is used when linkage is complicated. Iteratively the joint angles change to approach the goal position and orientation.

Jacobian is the *n* by *m* matrix relating differential changes of *q* to differential changes of *P* (*dP*).

Jacobian maps velocities in joint space to velocities in cartesian space

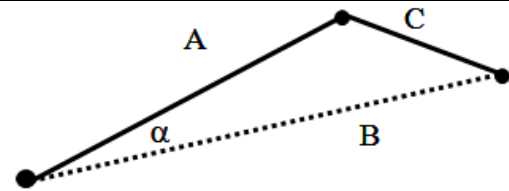

$$J(\theta)\dot{\theta} = V$$

$$f(\dot{\theta}) = P$$

$$J(\theta)d\theta = dP$$

$$J_{ij} = \frac{\partial f_i}{\partial \theta_j}$$

An example of Jacobian Matrix,

$$\begin{bmatrix} x \\ y \end{bmatrix} = \begin{bmatrix} f_1(\theta) \\ f_2(\theta) \end{bmatrix} = \begin{bmatrix} l_1 \cos\theta_1 + l_2 \cos\theta_2 + l_3 \cos\theta_3 \\ l_1 \sin\theta_1 - l_2 \sin\theta_2 + l_3 \sin\theta_3 \end{bmatrix}$$

$$\begin{bmatrix} \dot{x} \\ \dot{y} \end{bmatrix} = J \begin{bmatrix} \dot{\theta}_1 \\ \dot{\theta}_2 \\ \dot{\theta}_3 \end{bmatrix}$$

$$J = \begin{bmatrix} \frac{\partial f_1(\theta)}{\partial \theta_1} & \frac{\partial f_1(\theta)}{\partial \theta_2} & \frac{\partial f_1(\theta)}{\partial \theta_3} \\ \frac{\partial f_2(\theta)}{\partial \theta_1} & \frac{\partial f_2(\theta)}{\partial \theta_2} & \frac{\partial f_2(\theta)}{\partial \theta_3} \end{bmatrix} = \begin{bmatrix} -l_1 \sin\theta_1 & -l_2 \sin\theta_2 & -l_3 \sin\theta_3 \\ -l_1 \cos\theta_1 & -l_2 \cos\theta_2 & -l_3 \cos\theta_3 \end{bmatrix}$$

$$\theta \square J^{-1}(\theta) V$$

In the Jacobian method, the solving can be linearizable about  $\theta_k$  locally using small increments

**Dynamics**

Dynamics deals with the forces and torques that cause the motion of a system of bodies. Analogously to direct and inverse kinematics analysis, there is direct and inverse dynamic analysis.

**Jacobian matrix**

The joint angular velocity can be calculated with the Jacobian matrix.

$$\dot{\theta} = J^{-1} V_{ef}$$

Where  $\dot{\theta} = [\dot{\theta}_1, \dot{\theta}_2, \dots, \dot{\theta}_n]$  denotes an *n*-dimensional (*n* denotes the number of dof) vector of the joint angular velocities, *J* is the Jacobian of the robotic arm, and *V<sub>ef</sub>* the velocity of the end-effectors.

$$j = [j_1, j_2, \dots, j_n] \quad J_i = [Z_{i-1} \quad P_{i-1}]$$

$$Z_{i-1} = R_{i-1} [0 \ 0 \ 1]^T, P_{i-1} = R_{i-1} q_{i-1} + p_i$$

**Inverse dynamics**

The computation of the inverse dynamics is a prerequisite for evaluating any given design with given load and prescribed trajectory. Here we briefly recall the Lagrange-Euler formulation. The Lagrange equation is

$$\frac{d}{dt} \left( \frac{\partial L}{\partial \dot{\theta}_i} \right) - \frac{\partial L}{\partial \theta_i} = \tau_i; \quad i = 1, \dots, n$$

Where the Langraingian  $L = K-U = \sum_{i=1}^n (K_i - U_i)$ . For the *i*th link the K.E and P.E is given by

$$K_i = \frac{1}{2} m_i V_{c,i}^T V_{c,i} + \frac{1}{2} \omega_i^T I_i \omega_i \quad U_i = m_i g^T p_{c,i}$$

$$M(\theta)\ddot{\theta} + V(\theta, \dot{\theta}) + G(\theta) = \tau$$

$$M = \sum_{i=1}^n (J_{v,i}^T m_i J_{v,i} + J_{\omega,i}^T I_i J_{\omega,i})$$

Where  $J_{v,i}$  and  $J_{\omega,i}$  are 3\*n matrices. For revolute joints the *J*th coloumn vectors of  $J_{v,i}$  and  $J_{\omega,i}$  can be easily calculated.

$$J_{v,i}^j = Z_{j-1} * P_{c,i}^{j-1}, J_{\omega,i}^j = Z_{j-1} \text{ for } j \leq i$$

$$J_{v,i}^j = J_{\omega,i}^j = [0 \ 0 \ 0]^T \text{ for } i < j \leq n$$

$$m_i = m_{s,i} + m_{m,i} + m_{g,i}$$

**IV. FORMULATION OF DESIGN PROBLEM**

For formulating the design problem let we consider a drive train model for the single joint and for the harmonic drive gearbox, the gear efficiency varies depending on the output torque. With the inertia of motor and gear, the required motor torque for the *i*th joint is derived as

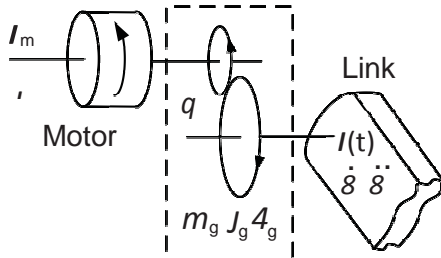

Fig.5: Schematic view of drive train model for a single joint.

$$\tau_{m,i} = \{ [J_m + J_g] \ddot{\theta}(t) \rho + \frac{\tau(t)}{\rho h g} \}_i; \quad i=1, \dots, 5$$

where *i* is the gear ratio

$J_g$  is the gear inertia with respect to the input motor axis

$J_m$  is the motor inertia

$g$  is the gear efficiency

**4.1 Motor Selecting Criteria**

The criteria for selecting motor and gearbox are applicable to each single joint, Motor selection criteria Motors for robotic arms are usually selected from two

motor groups, brushed and brushless DC motors. In selecting motors, the following three constraints must not be violated:

- **Nominal torque limit.** The nominal torque is the so-called maximum continuous torque. The root mean square (RMS) value  $\tau_{rms}$  of the required motor torque  $T_m$  has to be smaller than (5.25) equal to the nominal torque of the motor  $T_m$

$$\tau_{rms} \leq T_m$$

$$(5.26)$$

Where  $\tau_{rms} = \sqrt{\frac{1}{\Delta t} \int_0^{\Delta t} \tau_{m2}^2 dt}$  with  $\Delta t$  being the duration of characteristics of working cycle.

- **(5.28) Stall torque limit.** The stall torque is the peak torque of the motor. The required peak torque  $\tau_p$  has to be smaller than or equal to the stall torque  $\tau_m^{max}$  of the motor

$$\tau_p \leq \tau_m^{max}$$

Where  $\tau_p = \max |T_m|$

- **Maximum permissible speed limit.** The maximum permissible speed for DC motors is primarily limited by the commutation system. A further reason for limiting the speed is the rotor's residual mechanical imbalance which shortens the service life of the bearings. The required peak speed  $n_p$  corresponding to the motor has to be smaller than or equal to the maximum permissible speed  $N_m^{max}$  of the motor

$$n_p \leq N_m^{max}$$

Where  $n_p = \max \{ |2\pi \dot{\theta}(t) \cdot \rho| \}$

The inequalities (6.1) to (6.3) represent the constraints that must be fulfilled by any motor in the drive train.

**4.2 Gearbox selection criteria**

In the selection of gearboxes, the following three constraints are considered:

- **Rated output torque limit.** It is recommended by the Harmonic Drive gearbox manufacturer to use the RMC value for calculating rated torque. The RMC value is a measure of the accumulated fatigue on a structural component and reflects typical endurance curves of steel and aluminium. It is therefore relevant to gearbox lifetime, and this criterion has also been used in robotic applications. With this criterion, a constraint is derived

as

$$T_{g,i}^{max} \geq \max \{ |\tau(t, x) dt| \}_i$$

$$\tau_{rms} \leq T_g$$

$$N_{g,i}^{max} \leq \max \{ |\dot{\theta}(t) \cdot \rho| \}_i$$

Where  $\tau_{rms} = \sqrt[3]{\frac{1}{dt} \int_0^{\Delta t} \tau^3 dt}$  with  $\tau(t)$  being the required torque from the gearbox output.  $T_g$  is the limit for rated torque of the gearbox.

- **Maximum output torque limit.** The required peak torque  $\tau_g$  with respect to the output side has to be smaller than or equal to the allowable peak torque  $T_g^{max}$  of the harmonic drive

$$\tau_g \leq T_g^{max}$$

Where  $\tau_g = \max \{ |\tau(t)| \}$

- **Maximum permissible input speed limit.** The required maximum input peak speed  $n_{in}$  has to be smaller than or equal to the maximum permissible input speed  $N_g^{max}$  of a gearbox

$$n_{in} \leq N_g^{max}$$

Where  $n_{in} = \max \{ |\dot{\theta}(t) \cdot \rho| \}$

### 4.3 Objective function formulation

The objective of the optimization is to minimize the mass of the robotic arm. In this formulation, we minimize only the mass of the power transmission, while the mass of the arm structures remains constant. Therefore, the optimization task is to find the lightest combination of motor and gearbox for all five dof that fulfill all constraints associated with the motors and gearboxes. The objective function,  $f(x)$ , is defined as the sum of the mass of the motors and gears, as shown in the above Equation

$$\min_X f(X) = \int_{i=1}^5 \{ m_n(u_m) + m_g(u_g) \}_i$$

$$X = [u_m, u_g]$$

subject to

$$T_{m,i} \geq \sqrt{\frac{1}{\Delta t} \{ (J_m(X) + J_g(X)) \theta(t) \rho + \frac{\tau(t,x)}{\rho n_g} \}^2 \cdot dt}$$

$$T_{m,i}^{max} \geq \{ | (J_m(X) + J_g(X)) \theta(t) \rho + \frac{\tau(t,x)}{\rho n_g} | \}_i$$

$$N_{m,i}^{max} \geq \max \{ | 2\pi \dot{\theta}(t) \cdot \rho | \}_i$$

$$T_{g,i} \geq \sqrt[3]{\frac{1}{\Delta t} \int_0^{\Delta t} \tau_i^3(t, x) dt}$$

where design variables in  $x$  includes the index numbers of motors  $u_m = [u_{m1}, \dots \dots u_{m2}]$  and gearboxes  $u_g = [u_{g1}, \dots \dots u_{g2}]$  relative to databases containing commercially available components. So far, we have formulated the design problem as a discrete optimization problem, which can be solved by commercial available codes. We select a non-gradient method called Complex for this purpose. The implementation is outlined in the next section.

### 4.Procedure of optimization

The optimization method is developed as a Matlab and MSC.ADAMS co-simulation platform. The optimization algorithm is based on the Complex method, which is briefly discussed.

- **Optimization by Complex**

The Complex method is a non-gradient based optimization method, first presented by Box. In the Complex method, several possible designs (design population) are manipulated. The method is based on a feasible domain, containing a design population as a set of design points. The number of design points has to be greater than the number of independent design variables. The starting design points (initial population) are randomly generated, and evaluated through the objective function to check performance and constraint violation. Among all populations, the set of design variables having the minimal objective function is denoted as the best point  $x_b$ , while the one having the maximal objective function is denoted as the worst point  $x_w$ . Their corresponding values of objective function are noted as the best and worst values. The centroid point is calculated as

$$(6.7)$$

$$X_c = \frac{1}{m-1} \sum_{i=1}^m X_i, \quad X_i \neq X_b$$

$$X_i = [x_1, x_2, \dots \dots x_n]$$

The main idea of the Complex method is to replace the worst point by a new and better point. The new point is found by the reflection of the worst point through the centroid with a reflection coefficient, yielding the following expression for the new design point

$$X_{cand} = X_c + (X_c - X_w) \quad (6.10)$$

The coefficient  $\alpha = 1:3$  is used in this study, as recommended. The candidate point  $X_c$  and is checked through explicit and implicit constraints. When it conforms to the constraints,  $X_c$  and replaces  $X_w$ . This

method cannot handle the situation when the centroid is trapped in a local minimum. Therefore, the method has been modified such that the point moves toward the best point if it continues to be the worst one. To avoid the collapse of the algorithm, a random value is also added to the new point. The modified method to calculate the reflection point is given as

$$X_{cand}^{new} = \frac{1}{2} (X_{cand}^{old} + \epsilon X_c + (1-\epsilon)X_b + (X_c - X_b) (1-\epsilon) (2k - 1))$$

where k is a random number varying in the interval [0; 1], with

$$\epsilon = \left( \frac{n_r}{n_r + k_r + 1} \right)^{\frac{n_r + k_r - 1}{n_r}}$$

Here  $k_r$  is the number of times the same point has repeatedly been identified as the worst point, and  $n_r$  is a tuning parameter which is set to 4. The convergence criterion of the Complex method in this work is the difference between the best and worst objective function values is less than a user defined tolerance.

• **Dynamics model with MSC.ADAMS**

The drive requirements of the whole robotic arm system are determined from inverse kinematic and dynamic analysis within MSC.ADAMS. The inverse kinematic and dynamic analysis is developed as a simulation package, which will be called by the optimization program. To this end, the mass of motors and gearboxes are parameterized, while the trajectory of the robotic arm is prescribed.

For each variation of motors and gearboxes, the required motor torques are accurately calculated. The mass of distribution is updated during the optimization procedure. The inverse kinematic and dynamic analysis of the robotic arm in ADAMS follows a so-called master-slave approach. The basic concept of this approach is that we make two models of the robotic arm in ADAMS, a master model and a slave one. In the master model, the inverse kinematic analysis is executed to record the joint motions corresponding to the prescribed end-effector trajectory. In the slave model, the joint motion data is imported and imposed on the joints, and payload is also attached to the end-effector. Then the inverse dynamic calculation is performed to solve the required joint torques for actuating the robotic arm.

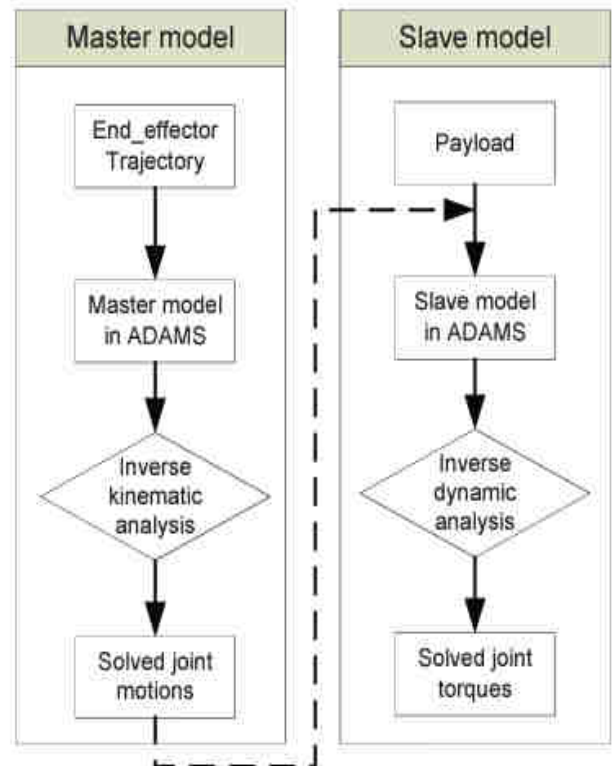

Fig.6: The procedure of inverse kinematic and dynamic analysis

In the master-slave approach, we can define different trajectories and payloads for the robotic arm model, which makes the model more flexible for different simulation conditions. This approach can be applicable to other serial and parallel robot systems.

• **Matlab-ADAMSCO-simulation platform**

The design optimization is mainly concerned of two tasks: the optimization routine and creation of a parametric dynamic simulation model. Both tasks can be performed on a Matlab-ADAMS co-simulation platform developed in this work. As shown in Fig. 3.6, the platform works with two modules. The ADAMS module is used to simulate the inverse kinematics and dynamics of the robotic arm. The Matlab module implements the Complex method to call the ADAMS simulation in batch mode.

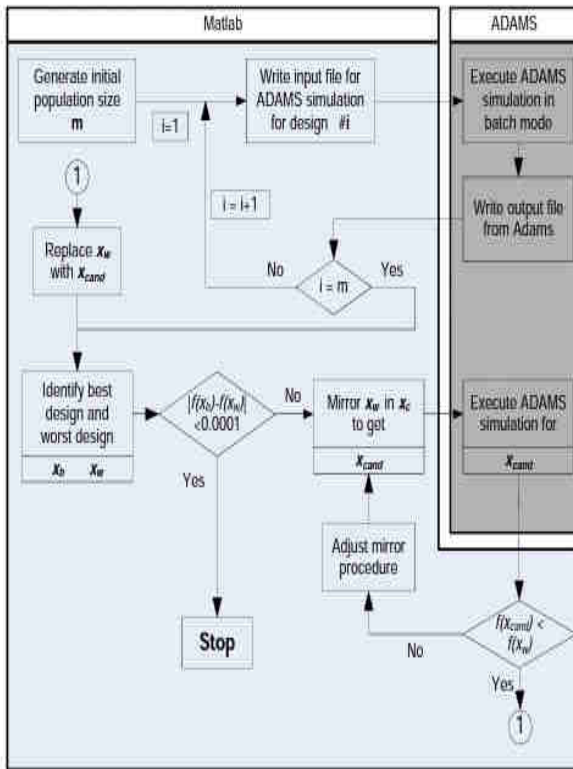

Fig.7: Diagram of the optimization routine in the co-simulation platform

### V. CONCLUSION

The main scope of this work is the development of a novel optimization approach for the design of robotic arms. A new optimization approach was developed for robot optimization to handle selection of motors and gearboxes, geometric and structural dimensions. This was achieved through stepwise optimization in three levels, starting from the constraints of motors and gearboxes, then the constraints of kinematic performance, and finally

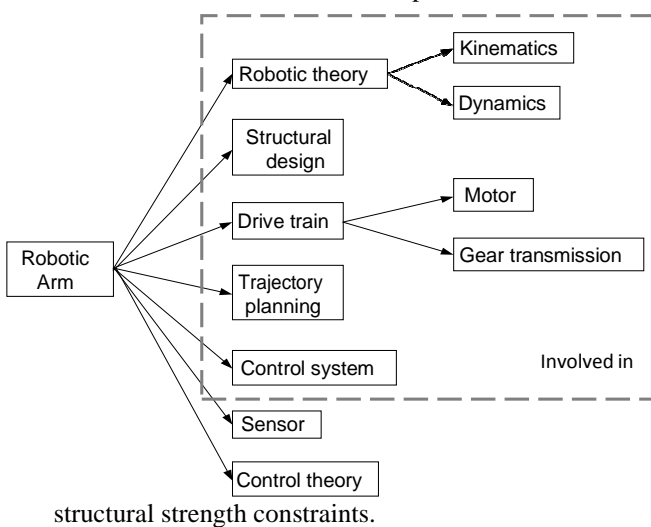

Fig.7: Different fields of technology involved in the architecture of robotic arms.

### Scope of work

The aim of this project is to design robotic arm. The works involved in the thesis are summarized in above Figure.

To reduce the weight of the robotic arm, optimization method will be developed in the design process. The approach of the project is summarized in the following steps: Study basic kinematics and dynamics of robotic arms.

Model and design a 5-dof robotic arm.

1. Optimize the robotic arm to reduce the weight.
2. Optimize the drive-train components (motors and gearboxes).
3. Optimize the link lengths together with the drive-train.
4. Optimize the structural dimensions, link lengths and the drive-train.

### VI. CONTRIBUTIONS

Within this project, the following contributions to the design and optimization of robotic arms were made

- New robotic optimization methods were developed. It is the first time to integrate the drive-train, kinematics and structural dimensions together in the optimization design of robots for minimal mass.
- Three extensible simulation platforms for robot simulation were developed. The platforms integrate numeric programming software with commercial dynamic simulation and FEA simulation software. The platforms could be easily expanded to contain more design variables on different robotic parameters and the corresponding constraints.
- A prototype of the 5-dof robotic arm was built to validate the optimization approaches. The prototype can be used to validate the different simulation models developed within the project.

### VII. FUTURE WORK

The optimization approach in this thesis focused on the mechatronic part of the robotic arm. Robot control is a key competence for robot manufacturers and is very important in order to get as much performance as possible out of a robot. Tuning of control parameters is also crucial for a robotic arm.

One possible direction of the future work is to combine the mechanical system design together with the control system design in the whole system optimization. Control parameters could be taken as design variables in the optimization.



**REFERENCES**

- [1] Deb S.R. Robotics technology and flexible automation, Tata McGraw-Hill Publishing Company Limited. New-Delhi, 2008.
- [2] Z. Bien, M. J. Chung, P. H. Chang, and D. S. Kwon. Integration of a rehabilitation robotic system (KARES II) with human-friendly man-machine interaction units. *Autonomous Robots*, 16:165–191, 2004.
- [3] R. M. Mahoney. The raptor wheelchair robot system. In M. Mokhtari, editor, *Integration of Assistive Technology in the Information Age*, pages 135–141. IOS press, 2001.
- [4] A. Albu-Schäffer, S. Haddadin, C. Ott, A. Stemmer, T. Wimböck, and G. Hirzinger. The DLR lightweight robot: design and control concepts for robots in human environments. *Industrial Robot*, 34(5):376–385, 2007.
- [5] JACO. Kinova technology, 2011. Available from: <http://www.kinovatechnology.com/>.
- [6] A. Jardon, A. Gimenez, R. Correal, R. Cabas, S. Martinez, and C. Balaguer. A portable light-weight climbing robot for personal assistance applications. *Industrial Robot*, 33(4):303–307, 2006.
- [7] H. H. Kwee. Integrated control of MANUS manipulator and wheel chair enhanced by environmental docking. *Robotica*, 16(5):491–498, 1998.
- [8] B. Rooks. The harmonious robot. *Industrial Robot*, 33(2):125–130, 2006.
- [9] A. Ananiev, D. Ignatova, and B. Iliev. An approach to the design of a lightweight reconfigurable robot arm for a mobile robot. *Problems of Engineering Cybernetics and Robotics*, 53:93–100, 2002.
- [10] Y. Ogura, H. Aikawa, Kazushi, H.-O. Lim, and A. Takanishi. Development of a new humanoid robot wabian-2. In *Proceedings of the 2006 IEEE International Conference on Robotics and Automation*, pages 76–81, 2006.
- [11] ASIMO. Asimo website, 2011. Available from: <http://world.honda.com/ASIMO/>.
- [12] A. Albers, S. Brudniok, J. Ottnad, C. Sauter, and K. Sedchaicharn. Upper body of a new humanoid robot - the design of armar iii. In *Proceedings of the 2006 IEEE-RAS International Conference on Humanoid Robots*, pages 308–313, 2006.
- [13] A. Edsinger-Gonzales and J. Weber. Domo: a force sensing humanoid robot for manipulation research. In *Proceedings of the 2004 IEEE-RAS International Conference on Humanoid Robots*, pages 273–291, 2004.
- [14] F. Roos, H. Johansson, and J. Wikander. Optimal selection of motor and gearhead in mechatronic applications. *Mechatronics*, 16(1):63–72, 2006.
- [15] K. Pasch and W. Seering. On the drive systems for high-performance machines. *ASME Journal of Mechanisms*, 106:102–108, 1983.
- [16] H. J. Van de Straete, J. de Schutter, P. Degezelle, and R. Belmans. Servo motor selection criterion for mechatronic applications. *IEEE Transactions on Mechatronics*, 3(1):43–50, 1998.
- [17] H. J. Van de Straete, J. de Schutter, and R. Belmans. An efficient procedure for checking performance limits in servo drive selection and optimization. *IEEE Transactions on Mechatronics*, 4(4):378–386, 1999.
- [18] P. Chedmail and M. Gautier. Optimum choice of robot actuators. *Journal of Engineering for Industry*, 112:361–367, 1990.
- [19] M. Pettersson and J. Ölvander. Drive train optimization for industrial robots. *IEEE Transactions on Robotics*, 25(6):1419–1423, 2009.
- [20] H. Elmqvist, H. Olsson, S. E. Mattsson, and D. Brück. Optimization for design and parameter estimation. In *Proceedings of the 4th International Modelica Conference*, pages 255–266, 2005.
- [21] A. Bowling and O. Khatib. Dynamic loading criteria in actuator selection for desired dynamic performance. *Advanced Robotics*, 17(7):641–656, 2003.
- [22] D. Z. Chen. Drive train configuration arrangement for gear coupled manipulators. *Journal of Robotic Systems*, 14(8):601–612, 1997.
- [23] Y. Zhu, J. Qiu, and J. Tani. Simultaneous optimization of a two-link flexible robot arm. *Journal of Robotic Systems*, 18(1):29–38, 2001.
- [24] B. K. Rout and R. K. Mittal. Optimal design of manipulator parameter using evolutionary optimization techniques. *Robotica*, 28:381–395, 2010.
- [25] P. S. Shiakolas, D. Koladiya, and J. Kebrle. Optimum robot design based on task specifications using evolutionary techniques and kinematic, dynamic, and structural constraints. *Inverse Problems in Science and Engineering*, 10(4):359–375, 2010.
- [26] Z. Shiller and S. Sundar. Design of robotic manipulators for optimal dynamic performance. In *Proceedings of the 1991 IEEE International Conference on Robotics and Automation*, pages 344–349, 1991.
- [27] O. Khatib and J. Burdick. Optimization of dynamics in manipulator design: the operational space for

- formulation. *International Journal of Robotics and Automation*, 2(2):90–98, 1987.
- [28] A. Albers, J. Ottnad, H. Weiler, and P. Haeussler. Methods for lightweight design of mechanical components in humanoid robots. In *Proceedings of the 7th IEEE-RAS International Conference on Humanoid Robots*, pages 609– 615, 2007.
- [29] J. Roy, R. P. Goldberg, and L. L. Whitcomb. Structural design, analysis, and performance evaluation of a new semi-direct drive robot arm: Theory and experiment. *IEEE/ASME Transactions on Mechatronics*, 9(1):10–19, 2004.
- [30] A. Pil and H. Asada. Rapid recursive structure redesign for improved dynamics of a single link robot. *ASME Journal of Dynamic Systems, Measurement, and Control*, 117(4):520–526, 1995.
- [31] M. J. Box. A new method of constrained optimization and a comparison with other methods. *Computer Journal*, 8:42–52, 1965.